



The STRATA PANEL collection by Woodzco introduces a renewed approach to architectural wood panels, combining precise engineering, refined aesthetics, and high-quality Canadian manufacturing. Its distinctive profile transforms surfaces into expressive, contemporary architectural elements.

With more than four (4) possible configurations and four (4) standard wood veneer species available in 8- and 10-foot length, this collection, with its engineered composition and clean lines, brings depth, rhythm, and elegance to interior spaces.

Manufactured in Canada to the highest industry standards, with a strong commitment to acoustic performance and tailor-made solutions.

Key features

- » An ideal choice for residential, commercial, and institutional projects
- » Quick and easy-to-install rigid decorative architectural wood panels
- » Designed for interior installation on walls, ceilings and custom-made furniture
- » Four standard species of wood veneer
- » Customization available for all components
- » Optional finishing trims available



CAN/ULC S102 FSI < 25 SDI < 50
ASTM E-84 CLASS A

Specifications

WOOD VENEER SPECIES	Standard wood veneer: Maple (flat cut), White Oak (rift cut), Cherry (flat cut) and Walnut (flat cut)
PANEL SIZES	<ul style="list-style-type: none"> 8-foot length panel : 10-3/4" x 95" (273 mm x 2 413 mm) 10-foot length panel : 10-3/4" x 119" (273 mm x 3 023 mm)
ASSEMBLY	Pre-assembled
WOOD BLADES	<ul style="list-style-type: none"> Natural or Mass tinted Black Moisture Resistant (MR) MDF - Fire rated (FR) Various standard sizes available (refer to the configuration chart) Wood Veneer on two (2) sides of the MDF for increased stability Available only with premium matte oil finish, clear or colored
CUSTOMIZATION	*Custom options available (minimum order of 400 sq.ft.)

Technical data

FIRE PERFORMANCE	<ul style="list-style-type: none"> CAN/ULC S102 (FSI < 25; SDI < 50) ASTM E-84 (Class A)
ENVIRONMENT	<ul style="list-style-type: none"> LEED v5 FSC certification of the product available upon request only No Added Formaldehyde (NAF) product available
USE	For interior uses only
SHIPPING	Woodzco products are carefully packaged at the factory and shipped in bulk on wooden pallets
SITE CONDITIONS	<ul style="list-style-type: none"> Wood products are naturally hygroscopic and must be stored flat, installed, and maintained in a controlled indoor environment Temperature: maintain between 50 °F and 86 °F (10 °C and 30 °C) Relative humidity: maintain between a minimum of 25 % and a maximum of 55 % (with no more than 20 % difference between maximum and minimum) <p>Failure to comply with one or more of these on-site conditions will void Woodzco's limited warranty</p>
WARRANTY	Three (3) year warranty on all Woodzco products. Please refer to Woodzco's limited warranty on our website for full details

LEED V5	RECYCLED CONTENT: UP TO 95%
MATERIALS AND RESSOURCES (MR)	INDOOR ENVIRONMENTAL QUALITY (IEQ)
MRc3 Low Emitting Materials ✓	EQc2 Occupant Experience ✓
VOC Emissions (CDPH) ✓	Option 1 Biophilic ✓
Formaldehyde Emissions (CARB) ✓	Path 1 Integrated Biophilic Design ✓
	Option 4 Sound Environment ✓
	Third parties CDPH ✓
	Pre-consumer Recycled ✓



CONFIGURATIONS

STRATA PANEL 2403

<ul style="list-style-type: none"> Quantity of blades: 10 Panel width: 10-3/4" (273 mm) Wood blade sizes: 15/16" x 1/2" (24 mm x 13 mm) Space between blades: 1/8" (3 mm) 	<ul style="list-style-type: none"> Panel thickness: 1/2" (13 mm) Panel area: 7.09 sq.ft (95" length); 8.88 sq.ft (119" length) Average weight: 0.8 kg/sq.ft. (1.7 lbs/sq.ft.)
---	--

PRODUCT CODE	WOOD	FINISHING	MDF
ITEM	VENEER	WOOD COLOR	COLOR
SPV 1001N MP__L	Maple	See box	Natural
SPV 1001B WO__L	White Oak	See box	Black
SPV 1001N WO__L	White Oak	See box	Natural
SPV 1001B CY00_L	Cherry	Natural (00)	Black
SPV 1001B WN00_L	Walnut	Natural (00)	Black

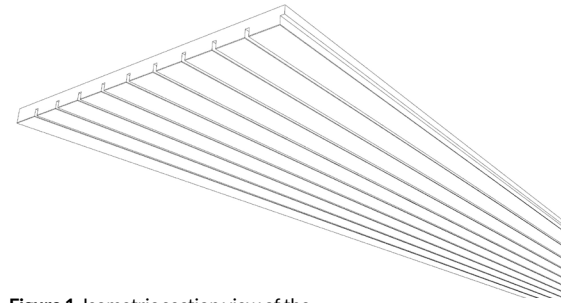

Figure 1. Isometric section view of the STRATA panel 2403.



Figure 2. Plan view of the STRATA panel 2403.

STRATA PANEL 2712

<ul style="list-style-type: none"> Quantity of blades: 7 Panel width: 10-3/4" (273 mm) Wood blade sizes: 1-1/16" x 1/2" (27 mm x 13 mm) Space between blades: 1/2" (12 mm) 	<ul style="list-style-type: none"> Panel thickness: 1/2" (13 mm) Panel area: 7.09 sq.ft (95" length); 8.88 sq.ft (119" length) Average weight: 0.8 kg/sq.ft. (1.7 lbs/sq.ft.)
--	--

PRODUCT CODE	WOOD	FINISHING	MDF
ITEM	VENEER	WOOD COLOR	COLOR
SPV 0701N MP__L	Maple	See box	Natural
SPV 0701B WO__L	White Oak	See box	Black
SPV 0701N WO__L	White Oak	See box	Natural
SPV 0701B CY00_L	Cherry	Natural (00)	Black
SPV 0701B WN00_L	Walnut	Natural (00)	Black

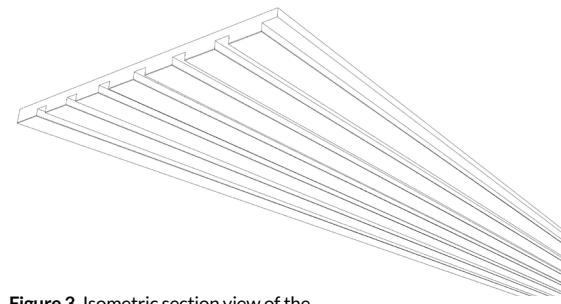

Figure 3. Isometric section view of the STRATA panel 2712.



Figure 4. Plan view of the STRATA panel 2712.

Finishing Wood Color

- Maple and White Oak are available in six (6) standard colors: Natural (00), White (01), Gray (02), Medium Brown (03), Dark Brown (04) and Black (06)
- Cherry and Walnut are only available in Natural (00)

CONFIGURATIONS

STRATA PANEL 6206

<ul style="list-style-type: none"> Quantity of blades: 4 Panel width: 10-3/4" (273 mm) Wood blade sizes: 2-7/16" x 1/2" (62 mm x 13 mm) Space between blades: 1/4" (6 mm) 	<ul style="list-style-type: none"> Panel thickness: 1/2" (13 mm) Panel area: 7.09 sq.ft (95" length); 8.88 sq.ft (119" length) Average weight: 0.8 kg/sq.ft. (1.7 lbs/sq.ft.)
---	--

PRODUCT CODE	WOOD	FINISHING	MDF
ITEM	VENEER	WOOD COLOR	COLOR
SPV 0401N MP__L	Maple	See box	Natural
SPV 0401B WO__L	White Oak	See box	Black
SPV 0401N WO__L	White Oak	See box	Natural
SPV 0401B CY00_L	Cherry	Natural (00)	Black
SPV 0401B WN00_L	Walnut	Natural (00)	Black

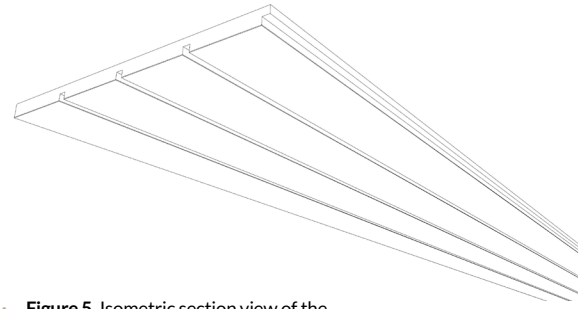

Figure 5. Isometric section view of the STRATA panel 6206.



Figure 6. Plan view of the STRATA panel 6206.

STRATA PANEL 13006

<ul style="list-style-type: none"> Quantity of blades: 2 Panel width: 10-3/4" (273 mm) Wood blade sizes: 5-1/8" x 1/2" (130 mm x 13 mm) Space between blades: 1/4" (6 mm) 	<ul style="list-style-type: none"> Panel thickness: 1/2" (13 mm) Panel area: 7.09 sq.ft (95" length); 8.88 sq.ft (119" length) Average weight: 0.8 kg/sq.ft. (1.7 lbs/sq.ft.)
---	--

PRODUCT CODE	WOOD	FINISHING	MDF
ITEM	VENEER	WOOD COLOR	COLOR
SPV 0201N MP__L	Maple	See box	Natural
SPV 0201B WO__L	White Oak	See box	Black
SPV 0201N WO__L	White Oak	See box	Natural
SPV 0201B CY00_L	Cherry	Natural (00)	Black
SPV 0201B WN00_L	Walnut	Natural (00)	Black

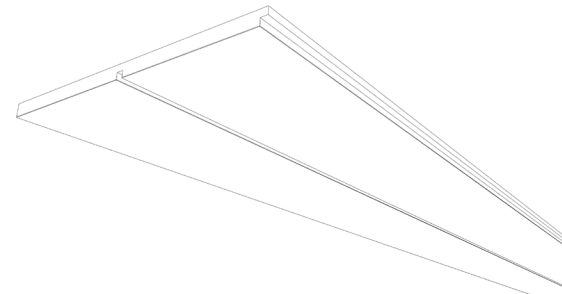

Figure 7. Isometric section view of the STRATA panel 13006.

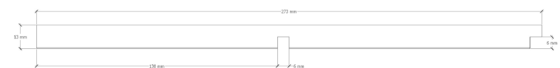
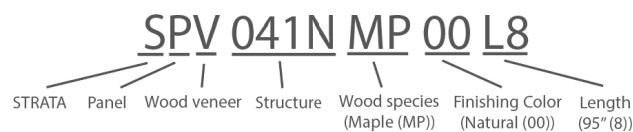

Figure 8. Plan view of the STRATA panel 13006.

Finishing Wood Color

- Maple and White Oak are available in six (6) standard colors: Natural (00), White (01), Gray (02), Medium Brown (03), Dark Brown (04) and Black (06)
- Cherry and Walnut are only available in Natural (00)

EXAMPLE ITEM NUMBER KEY



ACCESSORIES

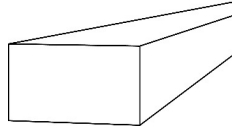

FINISHING TRIMS in solid wood (style 2403)



PRODUCT CODE	SIZES		WOOD	COLOR
ITEM	MM	INCHES	SPECIES	FINISHING
SAS 10T MP_ L_	24 x 13	15/16 x 1/2	Maple	See box
SAS 10T WO_ L_	24 x 13	15/16 x 1/2	White Oak	See box
SAS 10T CY00 L_	24 x 13	15/16 x 1/2	Cherry	See box
SAS 10T WN00 L_	24 x 13	15/16 x 1/2	Walnut	See box

FINISHING TRIMS in solid wood (style 2712)

PRODUCT CODE	SIZES		WOOD	COLOR
ITEM	MM	INCHES	SPECIES	FINISHING
SAS 07T MP_ L_	27 x 13	1-1/16 x 1/2	Maple	See box
SAS 07T WO_ L_	27 x 13	1-1/16 x 1/2	White Oak	See box
SAS 07T CY00 L_	27 x 13	1-1/16 x 1/2	Cherry	See box
SAS 07T WN00 L_	27 x 13	1-1/16 x 1/2	Walnut	See box

Finishing Wood Color

1. Maple and White Oak are available in six (6) standard colors: Natural (00), White (01), Gray (02), Medium Brown (03), Dark Brown (04) and Black (06)
2. Cherry and Walnut are only available in Natural (00)

NOTE: For finishing trims in solid wood (style 6206 & 13006), please contact your Woodzco representative.

INSTALLATION

Refer to the installation guide for complete details.

FINISHING

Oil Colors

Available in six (6) standard colors with a premium matte oil finish with custom options available*



Wood Veneer Species

Available in four (4) standard wood veneer species, with additional wood species available upon request*



Finishing Wood Color

1. Maple and White Oak are available in six (6) standard colors: Natural (00), White (01), Gray (02), Medium Brown (03), Dark Brown (04) and Black (06)
2. Cherry and Walnut are only available in Natural (00)

Panel lengths

Available in two (2) standard lengths (L): 95" (8) & 119" (10)

Disclaimer: A single sample may not accurately represent the full range of natural variations that can be expected. Due to the inherent properties and characteristics of wood, these samples should be considered an approximation of the effect that may be achieved. Some wood species exhibit greater natural appearance variations than others. We have made every effort to make the colors as accurate as possible. Please allow a tolerance of 1/16" in the actual dimensions of all our products. Due to continual product improvement, the information contained in this document is subject to change without notice. Woodzco assumes no responsibility for any errors or omissions that may have occurred inadvertently in this document.

*For further information, contact your Woodzco representative. Certain conditions apply.